

IP65 LED highbay luminaire

IP65 LED high bay luminaire for single point suspension. Efficient lens technology offering glare control and wide beam angle of 90° for homogeneous illumination. Housing design allows air flow cooling of the luminaire to ensure optimum performance in industrial environments. Total luminous flux: 30000 lm, Luminaire input power: 195 W, Luminaire efficacy: 154 lm/W, correlated colour temperature (CCT) 4000K, Lifetime: 50.000hrs @L80. Colour Rendering: CRI > 80, Chromaticity tolerance (initial MacAdam): 5. Including tool free connector, eye bolt and chain quick link. Wide voltage driver 100-277V AC 50/60Hz. Surge protection up to 4kV. Pre-wired with mains cable (15 cm). Available accessories: Plug&Play Emergency kit for 3 hour emergency conversion, stirrup, MWS-, PIR Sensor and remote for commissioning. Lumen package adjustable on site by 3 steps (FLEX1: 30000 lm (195W), FLEX2: 25000 lm (160W), FLEX3: 20000 lm (130W)). Detailed power setting information available on [www.THORNeco.com](http://www.THORNeco.com). Dimensions: Ø380 x 130 mm, weight: 3.13 kg.

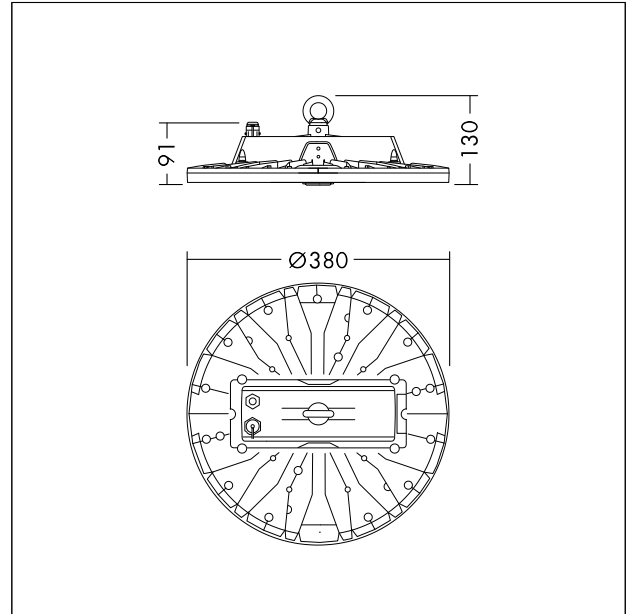

TE\_BORISF\_F\_L\_PERSP\_ZHAGA.jpg



TE\_BORISF\_M\_L.wmf

Light Distribution

STD - standard

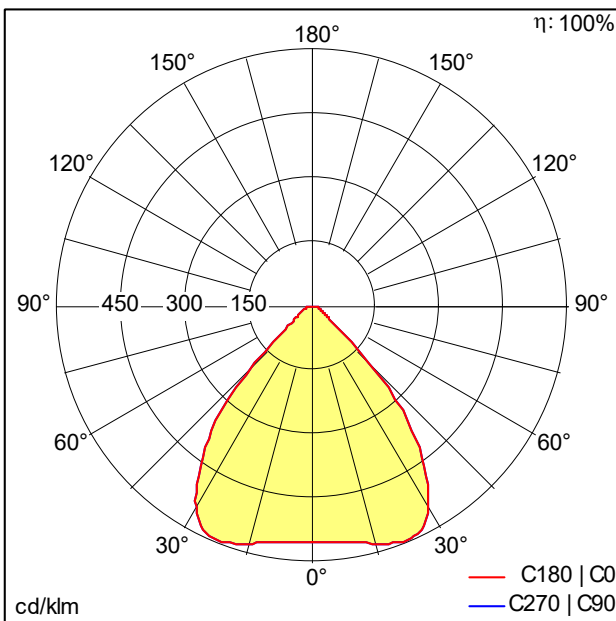

TE\_BORIS\_FLEX\_L\_30000\_840\_FLEX1.ltd

- Light Source: LED
- Luminaire luminous flux\*: 30000 lm
- Luminaire efficacy\*: 154 lm/W
- Colour Rendering Index min.: 80
- Correlated colour temperature\*: 4000 Kelvin
- Chromaticity tolerance (initial MacAdam): 5
- Rated median useful life\*: L80 50000 h at 25 °C
- Ballast: 1x LED\_Con
- Luminaire input power\*: 195 W Power factor = 0.9
- Dimming: STEPS dimmable to 65%
- Maintenance category CIE 97: E - Dust-proof IP5X
- Total harmonic distortion (THD): 20.00 %

This product contains a light source of energy efficiency class D.

All values marked with an \* are rated values. Connected electrical load and luminous flux are subject to an initial tolerance of +/- 10%, the most similar colour temperature is subject to an initial tolerance of +/- 150K. Unless stated otherwise, the values apply to an ambient temperature of 25°C.