

LED ceiling-recessed luminaire

LED ceiling-recessed luminaire, with improved perceived glare and microprismatic diffusor. Product height of only 27 mm: fits various ceiling types. Replaces conventional downlights 1x18W CFL and offers at least 50 % energy saving. Ceiling cutout Ø 165-170 mm. Total luminous flux: 1000 lm, Luminaire input power: 9.5 W, Luminaire efficacy: 105 lm/W correlated colour temperature (CCT) adjustable via switch for warm white (3000K), neutral white (3500K) or cold white (4000K) to suit application use. Lifetime: 50.000hrs @L80, Colour Rendering: CRI > 80. Chromaticity tolerance (initial MacAdam): 4. Body: backplate - steel, frame - aluminum, white finish (RAL9003). Light guide panel: PMMA. Diffuser: PC. IP44_IP20 from the room side. Connector for easy and tool-free wiring. Available accessories: Plug&Play "Just Emergency E3 KIT" for 3h emergency operation. Lumen package adjustable on site by 3 steps FLEX@4000K: (FLEX1 - 1000 lm (9,5W), FLEX2 - 850 lm (8W), FLEX3 - 650 lm (6W)). Detailed power setting information available on www.THORNeco.com. Dimensions: Ø181 x 27 mm, weight: 0.4 kg.

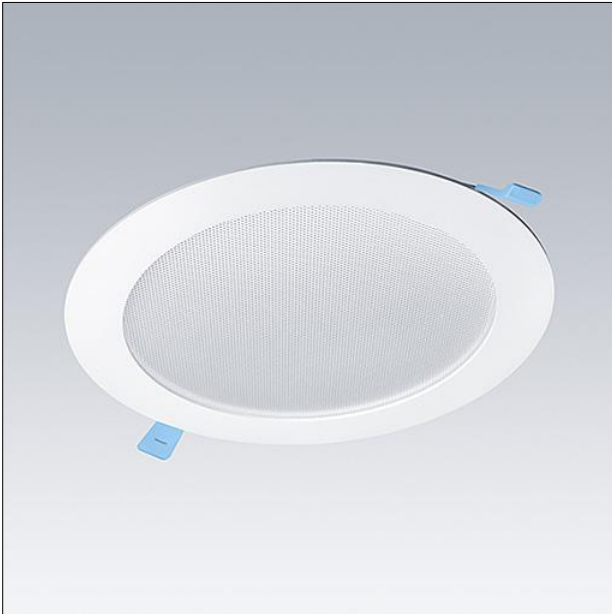

TE_ZOEVF_F_PERSP_UNLIT.jpg

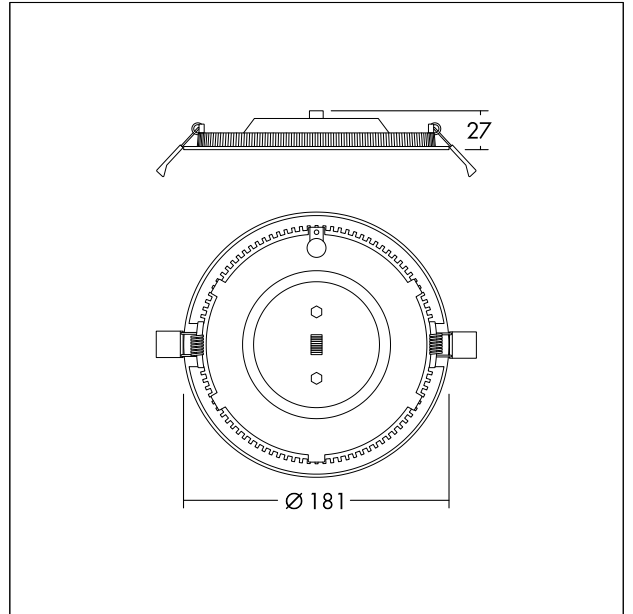

TE_ZOEVF_M_165.wmf

Light Distribution

STD - standard

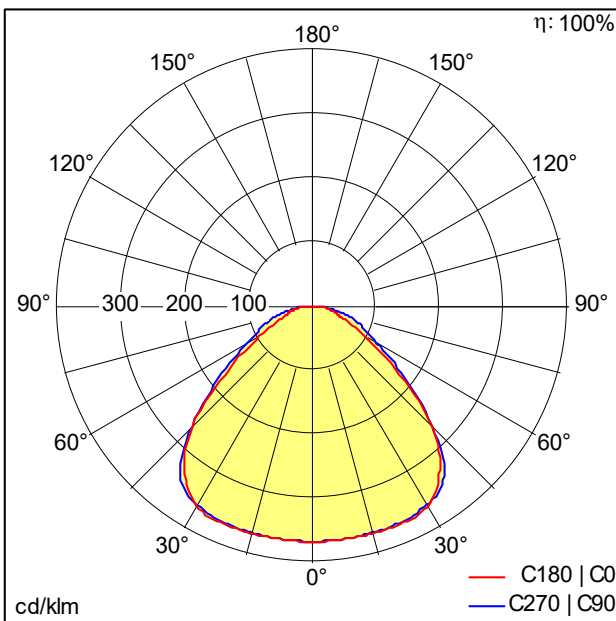

TE_ZOE_VARIO_FLEX_165_1000_840_FLEX1.ltd

- Light Source: LED
- Luminaire luminous flux*: 1000 lm
- Total emergency luminous flux: 315 lm
- Luminaire efficacy*: 105 lm/W
- Colour Rendering Index min.: 80
- Correlated colour temperature*: 3000-4000 Kelvin
- Chromaticity tolerance (initial MacAdam): 4
- Rated median useful life*: L80 50000 h at 25 °C
- Ballast: 1x LED_Con
- Luminaire input power*: 9.5 W Power factor = 0.9
- Dimming: STEPS dimmable to 65%
- Maintenance category CIE 97: D - Enclosed IP2X
- Total harmonic distortion (THD): 20.00 %

All values marked with an * are rated values. Connected electrical load and luminous flux are subject to an initial tolerance of +/- 10%, the most similar colour temperature is subject to an initial tolerance of +/- 150K. Unless stated otherwise, the values apply to an ambient temperature of 25°C.